

# WEB SENSORS

On-line monitoring and alarm indication

Temperature | Humidity | Dewpoint |  
Bar. pressure | CO<sub>2</sub> | Current | Events



- A solution for every need and every budget – **economy** and **premium** web sensors
- High quality, accurate and stable sensors
- Internal or external probes on the cable
- Power over Ethernet (PoE)
- Relay outputs in selected models



**OMET**  
since 1991

# Applications

These days there is a high demand for on-line monitoring and uninterruptable records of different type of values. If the ethernet net has direct connection to the internet, then all data could be sent immediately around the world without the need for any additional costs.

## Pharmaceuticals and laboratories

Monitoring of areas and places for storage of drugs at temperatures down to -200 °C.



## Technological processes and production

Monitoring of storage conditions and production processes in the temperature range from -200 °C to + 600 °C.

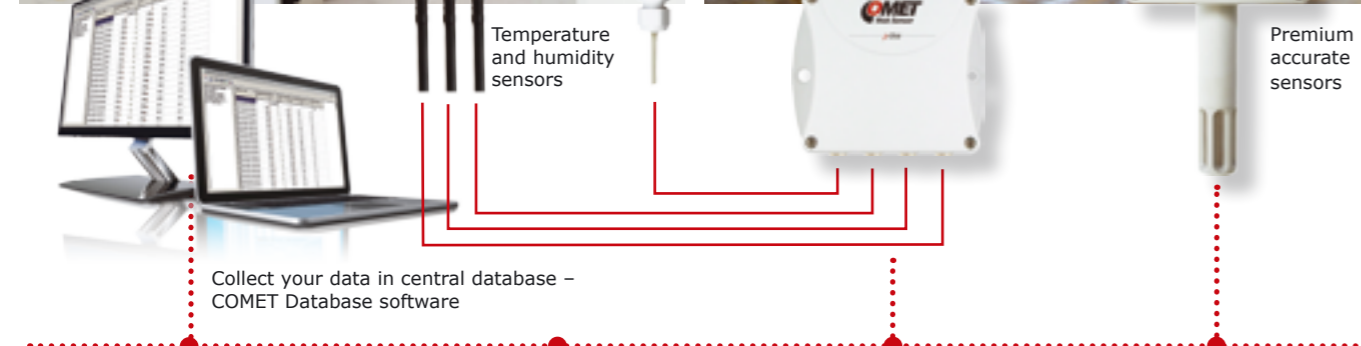

## Schools and interior spaces

Protect your children's health with timely control of air quality in buildings. With COMET CO<sub>2</sub> sensors you always see the exact CO<sub>2</sub> concentration.



## Food industry

Monitoring of critical variables in relation to HACCP regulations with the possibility of immediate alert to unforeseen events that could lead to the devaluation of goods.



## Server rooms

Monitoring of conditions in the data centers and in 19" racks, including detection of the state of flooding, opening / closing doors (windows), movement and smoke, etc.

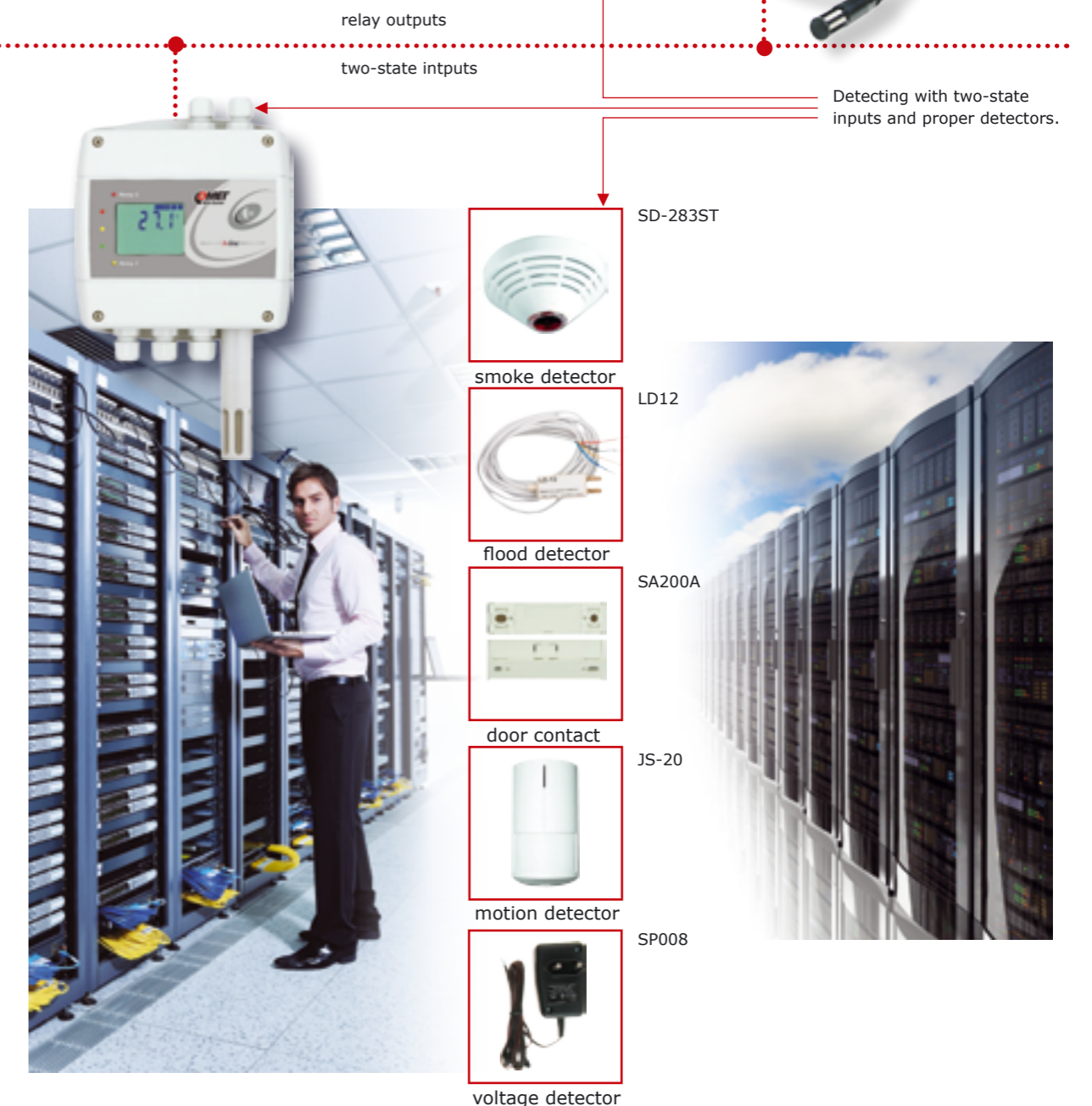

# On-line measurement and monitoring

Temperature \* Humidity \* Dew point \* Atm. Pressure \* CO<sub>2</sub> \* Current \* Events

Continuous monitoring of critical parameters such as temperature and relative humidity can be very easily done by the help of Web Sensors. This production line consists of sensors for measuring temperature, relative humidity, CO<sub>2</sub> concentration, atmospheric pressure, events and the 4-20mA signal. The last one allows measuring other physical quantities with third party sensors.

Measured values are accessible via powerful embedded web server which is accessible from personal computer or mobile devices like smartphones and tablets. History values can be exported for further processing by the CSV file. CSV file can be processed inside spreadsheet application like Microsoft Excel or OpenOffice Calc. CSV file can be downloaded from web pages or periodically sent as e-mail attachment.

**Current measured values** are available on-line directly on a web browser from anywhere, all you need to do is enter the IP address. Alarms are indicated by a red field.

**Graphs of actual values** can also be displayed through a web browser. You can display up to one thousand measured values.

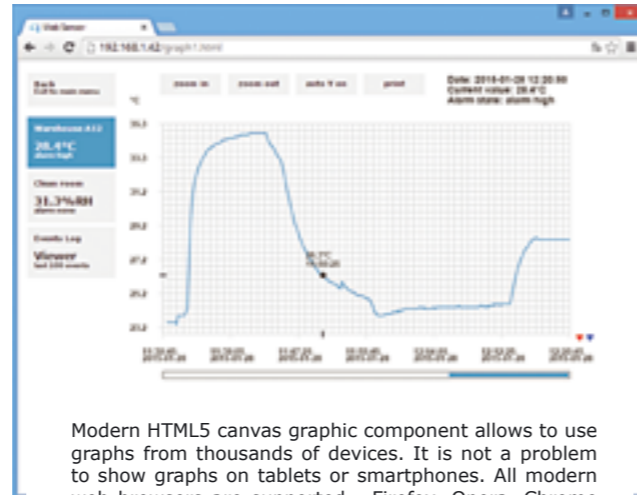

Modern HTML5 canvas graphic component allows to use graphs from thousands of devices. It is not a problem to show graphs on tablets or smartphones. All modern web browsers are supported - Firefox, Opera, Chrome or Microsoft Edge.

## Alarm Indication

Graphically \* Remotely via e-mail \* Via texts (with CDB software)

Upper and lower limits can be set for each channel. In case the limits are exceeded these critical situation is indicated remotely. It can be indicated by red field, e-mail or texts if data are transmitted to central COMET Database software. E-mails are also sent when values return back into safe range. SMTP authentication is supported, but SSL not. E-mails with CSV file attachment can be sent at selected intervals.

Time	Channel	Event	Value
11:43:33 2015-01-28	CHQ2 - Clean room	High Alarm	45.6
11:34:51 2015-01-28	CHQ2 - Clean room	High Alarm	33.8
11:31:45 2015-01-28	CHQ2 - Warehouse A12	High Alarm	23.5
11:29:50 2015-01-28	BNQ2 - Power supply	FAIL	
11:13:27 2015-01-28	BNQ3 - Main lock	locked	
11:13:21 2015-01-28	BNQ3 - Main lock	open	
11:13:05 2015-01-28	BNQ3 - Main lock	locked	
11:13:05 2015-01-28	BNQ2 - Power supply	FAIL	
11:13:05 2015-01-28	BNQ2 - Warehouse door	closed	

Minimum, maximum and alarm values together with a time stamp are recorded by the Event Log.



Alarms are indicated by a red field.

# Device settings

Web browser interface for settings \* Possibility of integration to third party systems

The device setup can be made by the TSensor software which can be downloaded for free from the manufacturer's website. The advantage of Web Sensors is possibility to providing of settings via web interface.

**Sensor settings** can also be done directly in a web browser in your PC, smartphone or tablet. All you need to do is enter the IP address of the sensor, open Settings and set up everything from communication to alarm e-mails.

**Configuration of the alarm e-mails.** Device can send warning e-mail when alarm on measured channel occurs. E-mail is also sent when alarm condition is cleared.

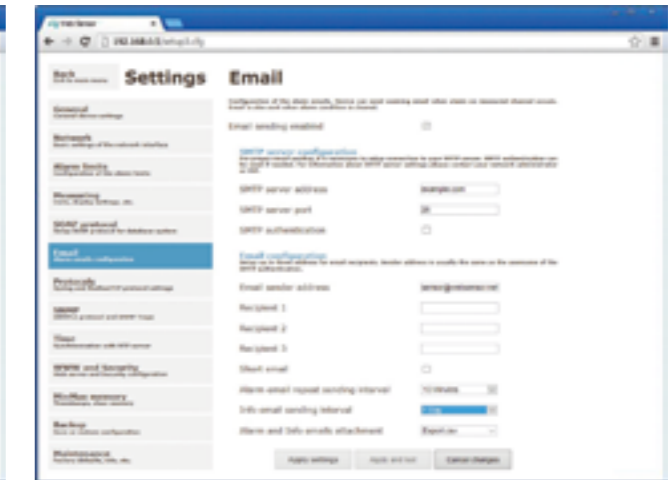
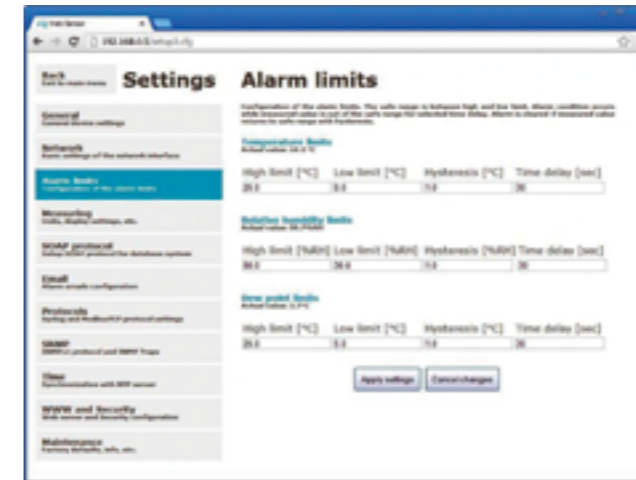

## Device communication

By connecting directly to a computer network the thermometer or humidity meter can be integrated into the control systems of different manufacturers using SNMP, MODBUS TCP, SOAP, syslog. Of course data in many formats is also available, for example XML and so on.



### ModbusTCP protocol

Modbus protocol for communication with SCADA systems or third party software. Devices use Modbus TCP protocol version. Two Modbus clients can be connected to the device at one moment.



### Actual values via XML

XML protocol for actual measured values reading. This protocol is suitable for Web Sensors integration into 3rd party SCADA systems.



### SNMP protocol

SNMP version 1 protocol for IT infrastructure. Using SNMP protocol you can read actual measured values, alarm statuses and alarm parameters. Via SNMP protocol is also possible to get last 1000 measured values from the history table. MIB tables with OID description are available.



### SNMP Trap

SNMP Trap for IT infrastructure. Web Sensors allow sending Traps to selected Trap receiver server. Traps are sent in case of alarm on channel or at error states like unable to send e-mail, unable to deliver SOAP message, etc.



### SOAP protocol

Web Sensors allow to send currently measured values via SOAP v1.1 protocol. The device sends values in XML format to the web server. The advantage of this protocol is that communication is initialized by the device side. Therefore it is not necessary to use port forwarding.



### Syslog protocol

Syslog protocol for IT infrastructure monitoring systems. Web Sensors allow sending text messages to selected Syslog server. Messages are sent in case of alarm on channel or at error states like unable to send e-mail, unable to deliver SOAP message, etc.



### SNTP protocol - time synchronization

Time synchronisation with SNTP server. Actual time is shown at web pages and is necessary for timestamps inside CSV files. Synchronisation interval can be set to one day or to one hour.

# Premium Web Sensors

Premium Web Sensors with Ethernet connection are designed for very accurate measurement of **temperature, relative humidity, CO<sub>2</sub> and barometric pressure** of air in non-aggressive environments. Measured values are according to device type. Devices with relative humidity measurement can show one of computed values: dew point temperature, absolute humidity, specific humidity, mixing ratio and specific enthalpy. Temperature units are °C or °F. Premium Web Sensor are equipped with LCD display where current values can be displayed.

Devices with **PoE** (page 10) or **relay outputs** (page 14) are also available.

## Without PoE

Connector for power adapter with output voltage 9-30 Vdc

The Ethernet RJ45 connector for cable connection

0 to 1000 ppm 😊  
1000 to 1200 ppm 😐  
1200 to 2000/10 000 ppm 😡  
Limits of LED indication may be changed by user

External mounting holes for easy and fast mounting without the need to take off lid cover

Display for current measured values

Air intakes for CO<sub>2</sub> measurement

Case of sensor is made of ABS which is very resistant to mechanical damage

RTD Pt1000 temperature sensor together with state-of-the-art capacitive polymer sensor

2. F5300 - Teflon (PTFE) sensor cover (white colour), with increased resistance against splashing water, non-absorbent surface, does not rust. Porous size 25µm. Temperature range -40°C to +125°C

3. F0000 - sintered bronze sensor cover for moderate aggressive environments. Filtering ability 0.025mm

1. Sensor cover F5200 (F5200B - black) with filter from stainless steel mesh. Filtering

Sensor protection caps

1. 2. 3.

Measured values		Temperature		Temperature, relative humidity		
SENSOR MODEL		T4511	T0510	T3510	T3511	T3511P
temperature	range	-200 to +600 °C	-30 to +80 °C	-30 to +80 °C	-30 to +105 °C	
	accuracy	±0.2 °C without temp. probe	±0.6 °C	±0.6 °C	±0.4 °C	
relative humidity *	range	-	-	0 to 100 % RH	0 to 100 % RH	
	accuracy	-	-	±2.5 % RH	±2.5 % RH	
computed humidity values		NO	NO	YES	YES	
supply voltage		9-30 V	9-30 V	9-30 V	9-30 V	
recommended calibration interval		two years	two years	one year	one year	
protection class of the case with electronics		IP30	IP30	IP30	IP30	
protection class of the sensor cover		-	-	IP40	IP40	
temperature operating range of the case with electronics		-30 to +80 °C	-30 to +80 °C	-30 to +80 °C	-30 to +80 °C	
temperature operating range of the measuring element		-	-	-30 to +80 °C	-30 to +105 °C	
humidity operating range without condensation		0 to 100 % RH	0 to 100 % RH	0 to 100 % RH	0 to 100 % RH	
barometric pressure operating range		-	-	-	-	to 2,5 MPa

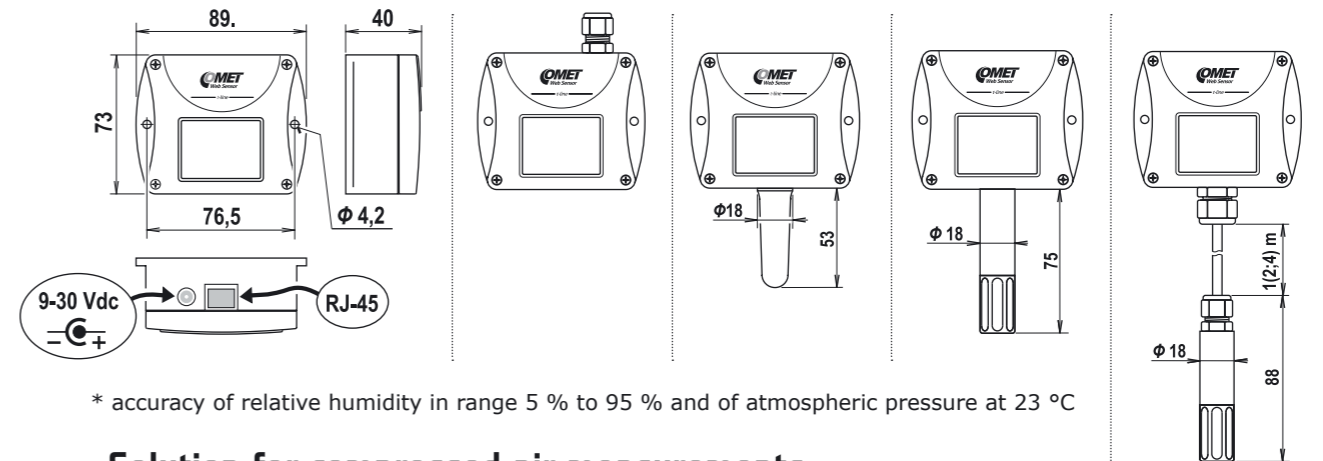

\* accuracy of relative humidity in range 5 % to 95 % and of atmospheric pressure at 23 °C

## Solution for compressed air measurements

**SH-PP** - Flow chamber (see number 4 at picture) for compressed air measurement up to 25 bars - stainless steel DIN 1.4301 inlet and outlet connection - G1/8 thread humidity probe connection - G1/2 thread screw-coupling not included.

The probe for measuring the moisture of compressed air should be placed directly on the pressure pipelines to achieve higher measurement accuracy and faster response times. But there are cases where such placement is not possible. The reason is the high air speed, high temperature, high pollution, small diameter pipes, etc. Such situation can be solved by placing the probe into the flow measuring chamber. The picture shows the basic layout of the sampling system with chamber SH-PP.

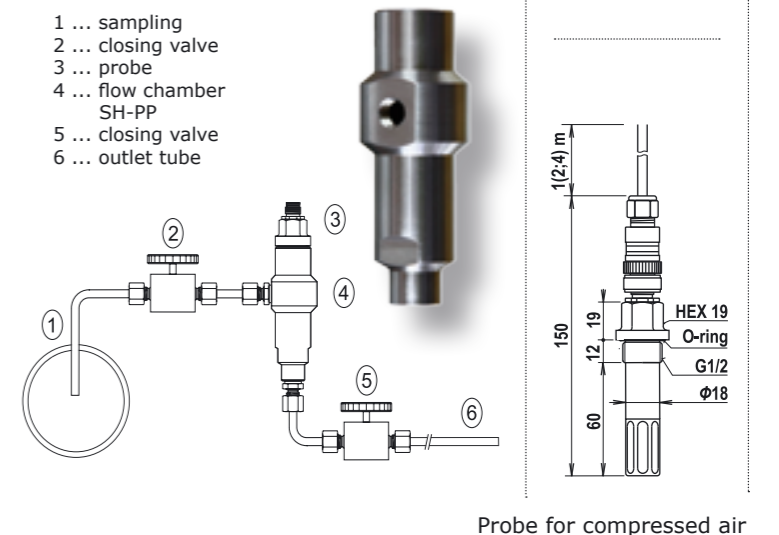

Probe for compressed air

Measured values		Temperature, relative humidity, atm. pressure		Atm. pressure	Temperature, relative humidity, CO <sub>2</sub>	CO <sub>2</sub>		
SENSOR MODEL		T7510	T7511	T2514	T6540	T5540	T5541	T5545
temperature	range	-30 to +80 °C	-30 to +105 °C	-	-30 to +80 °C	-	-	-
	accuracy	±0.6 °C	±0.4 °C	-	±0.6 °C	-	-	-
relative humidity **	range	0 to 100 % RH	0 to 100 % RH	-	0 to 100 % RH	-	-	-
	accuracy	±2.5 % RH	±2.5 % RH	-	±2.5 % RH	-	-	-
atm. pressure **	range	600 to 1100 hPa	600 to 1100 hPa	600 to 1100 hPa	-	-	-	-
	accuracy	±1.3 hPa	±1.3 hPa	±1.3 hPa	-	-	-	-
CO <sub>2</sub> ***	range	-	-	-	0 to 2000 ppm*	0 to 2000 ppm*	0 to 10000 ppm	0 to 2000 ppm*
	accuracy	-	-	-	± (50 ppm+2 % of measured value)	± (50 ppm+2 % of measured value)	± (110 ppm+5 % of measured value)	± (50 ppm+2 % of measured value)
computed humidity values		YES	YES	NO	YES	NO	NO	NO
supply voltage		9-30 V	9-30 V	9-30 V	9-30 V	9-30 V	9-30 V	9-30 V
recommended calibration interval		one year	one year	one year	one year	five years	five years	five years
protection class of the case with electronics		IP30	IP30	IP30	IP30	IP30	IP30	IP30
protection class of the sensor cover		IP40	IP40	-	IP40	-	IP 65	IP20
temperature operating range of the case with electronics		-30 to +80 °C	-30 to +80 °C	-30 to +80 °C	-30 to +60 °C	-30 to +60 °C	-30 to +80 °C	-30 to +60 °C
temperature operating range of the measuring element		-30 to +80 °C	-30 to +105 °C	-	-30 to +80 °C	-	-40 to +60 °C	-
humidity operating range without condensation		0 to 100 % RH	0 to 100 % RH	0 to 100 %RH	5 to 95 % RH	5 to 95 % RH	0 to 100 % RH	5 to 95 % RH
barometric pressure operating range		-	-	-	850 to 1100 hPa	850 to 1100 hPa	850 to 1100 hPa	850 to 1100 hPa

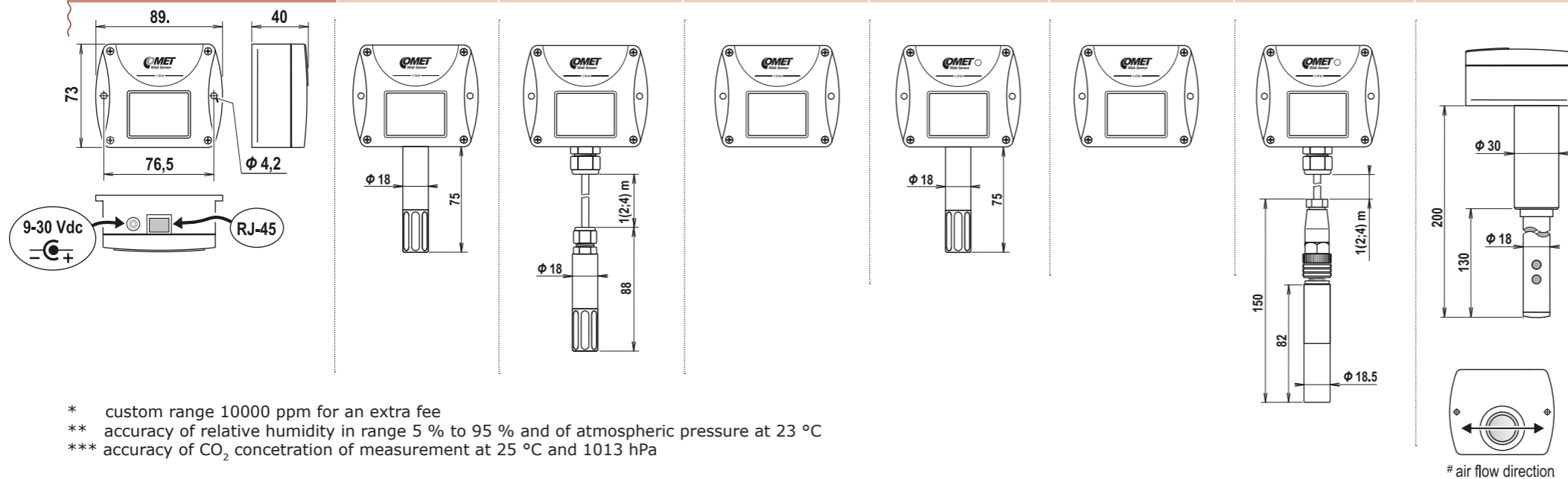

## Computed values

### Specific humidity

Accuracy: ±2.1 g/kg at ambient temperature T < 35 °C  
 Range: 0 to 550 g/kg

### Dew point temperature

Accuracy: ±1.5 °C at ambient temperature T < 25 °C and relative humidity RH > 30 %, for more details see manual  
 Range: -60 to +80 °C (-76 to 176 °F)

### Mixing ratio

Accuracy: ±2.2 g/kg at ambient temperature T < 35 °C  
 Range: 0 to 995 g/kg

### Absolute humidity

Accuracy: ±3 g/m<sup>3</sup> at ambient temperature T < 25 °C  
 for more details see manual  
 Range: 0 to 400 g/m<sup>3</sup>

### Specific enthalpy

Accuracy: ± 4 kJ/kg at ambient temperature T < 25 °C  
 Range: 0 to 995 kJ/kg

## Device without PoE - connection procedure

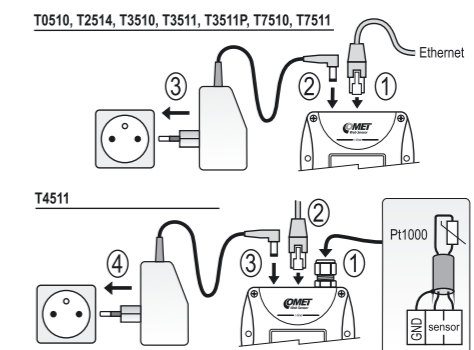

**A1515**  
 Switching power supply unit for Ethernet transmitters Tx5xx, Hx5xx.

# Premium Web Sensors

With PoE

The Ethernet RJ45 connector for cable connection. Where power over Ethernet is used, the network infrastructure must be **compatible with IEEE 802.3af standard**

Connector for power adapter with output voltage 4.9 - 6.1 Vdc

Case of sensor is made of ABS which is very resistant to mechanical damage

Display for current measured values

Mounting holes for mounting the unit on the wall

Sensor protection caps

RTD Pt1000 temperature sensor together with state-of-the-art capacitive polymer sensor

1. Sensor cover F5200 (F5200B - black) with filter from stainless steel mesh. Filtering ability is 25µm

2. F5300 - Teflon (PTFE) sensor cover (white colour), with increased resistance against splashing water, non-absorbent surface, does not rust. Porous size 25µm. Temperature range -40°C to +125°C

3. F0000 - sintered bronze sensor cover for moderate aggressive environments. Filtering ability 25µm

Measured values		Temperature		Temperature, relative humidity	
SENSOR MODEL		T4611	T0610	T3610	T3611
temperature	range	-200 to +600 °C	-20 to +60 °C	-20 to +60 °C	-30 to +105 °C
	accuracy	±0.2 °C without temperature probe	±0.6 °C	±0.6 °C	±0.4 °C
relative humidity*	range	-	-	0 to 100 % RH	0 to 100 % RH
	accuracy	-	-	±2.5 %RH	±2.5 % RH
atm. pressure*	range	-	-	-	-
	accuracy	-	-	-	-
computed humidity values		NO	NO	YES	YES
supply voltage		4.9 - 6.1 V	4.9 - 6.1 V	4.9 - 6.1 V	4.9 - 6.1 V
Power over Ethernet (PoE) according to IEEE 802.3af		YES	YES	YES	YES
recommended calibration interval		two years	two years	one year	one year
protection class of the case with electronics		IP30	IP30	IP30	IP30
protection class of the sensor cover		-	-	IP40	IP40
temperature operating range of the case with electronics		-20 to +60 °C	-20 to +60 °C	-20 to +60 °C	-20 to +60 °C
temperature operating range of the measuring element		-	-	-20 to +60 °C	-30 to +105 °C
humidity operating range without condensation		0 to 100 % RH	0 to 100 % RH	0 to 100 % RH	0 to 100 % RH

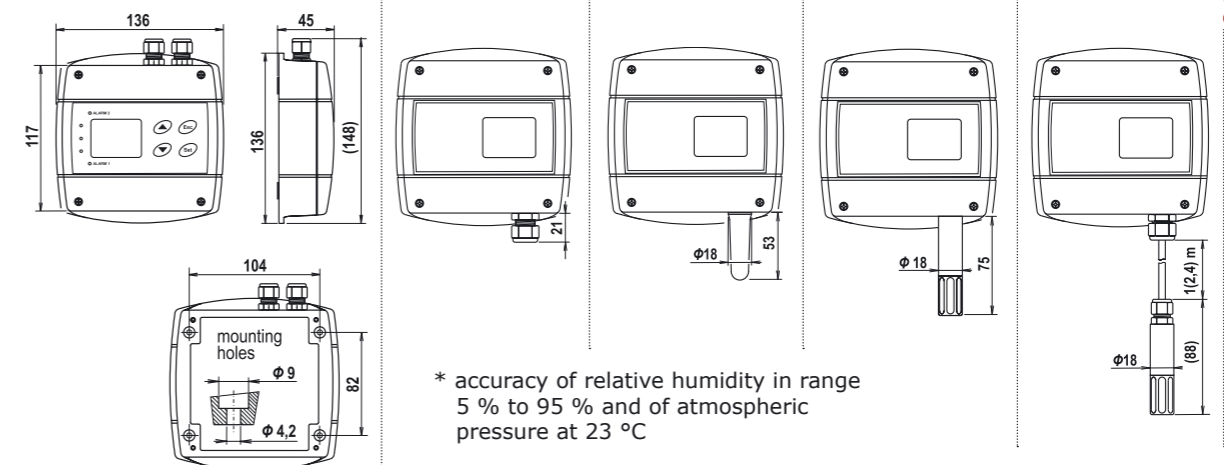

## Mounting accessories for sensors with stem or external probe



**PP90** - Right-angled stainless steel flange.



**PP4** - plastic flat circular flange

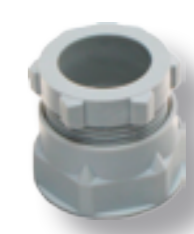

**SP004** - Plastic gland for direct mounting of the humidity probe to a 29 mm diameter hole.

Measured values		Temperature, relative humidity, atm. pressure			CO <sub>2</sub>		Temperature relative humidity, CO <sub>2</sub>	
SENSOR MODEL		T7610	T7611	T7613D	T5640	T5641	T6640	T6641
tempera- ture	range	-20 to +60 °C	-30 to +105 °C	-30 to +105 °C			-20 to +60 °C	-30 to +105 °C
	accuracy	±0.6 °C	±0.4 °C	±0.6 °C			±0.6 °C	±0.4 °C
relative humidity*	range	0 to 100 % RH	0 to 100 % RH	0 to 100 % RH			0 to 100 % RH	0 to 100 % RH
	accuracy	±2.5 % RH	±2.5 % RH	±2.5 % RH			±2.5 % RH	±2.5 % RH
atm. pres- sure*	range	600 to 1100 hPa	600 to 1100 hPa	600 to 1100 hPa			850 to 1100 hPa	850 to 1100 hPa
	accuracy	±1.3 hPa	±1.3 hPa	±1.3 hPa			±1.3 hPa	±1.3 hPa
CO <sub>2</sub>	range				± (50 ppm+2 % of measured value)	± (100 ppm+5 % of measured value)	± (50 ppm+2 % of measured value)	± (100 ppm+5 % of measured value)
	accuracy				2000 ppm	10000 ppm	2000 ppm	10000 ppm
computed humidity values		YES	YES	YES			YES	YES
supply voltage		4.9 - 6.1 V	4.9 - 6.1 V	4.9 - 6.1 V	5.0 - 6.1 V	5.0 - 6.1 V	5.0 - 6.1 V	5.0 - 6.1 V
Power over Ethernet (PoE) according to IEEE 802.3af		YES	YES	YES	YES	YES	YES	YES
recommended calibration interval		one year	one year	one year	five years	five years	one year	one year
protection class of the case with electronics		IP30	IP30	IP30	IP30	IP30	IP30	IP30
protection class of the sensor cover		IP40	IP40	IP40		IP65	IP40	IP40
temperature operating range of the case with electronics		-20 to +60 °C	-20 to +60 °C	-20 to +60 °C	-20 to +60 °C	-30 to +80 °C	-20 to +60 °C	-30 to +80 °C
temperature operating range of the RH sensor		-20 to +60 °C	-30 to +105 °C	-30 to +105 °C			-20 to +60 °C	-30 to +105 °C
humidity operating range without condensation		0 to 100 % RH	0 to 100 % RH	0 to 100 % RH	0 to 95 % RH	0 to 100 % RH	0 to 95 % RH	0 to 100 % RH

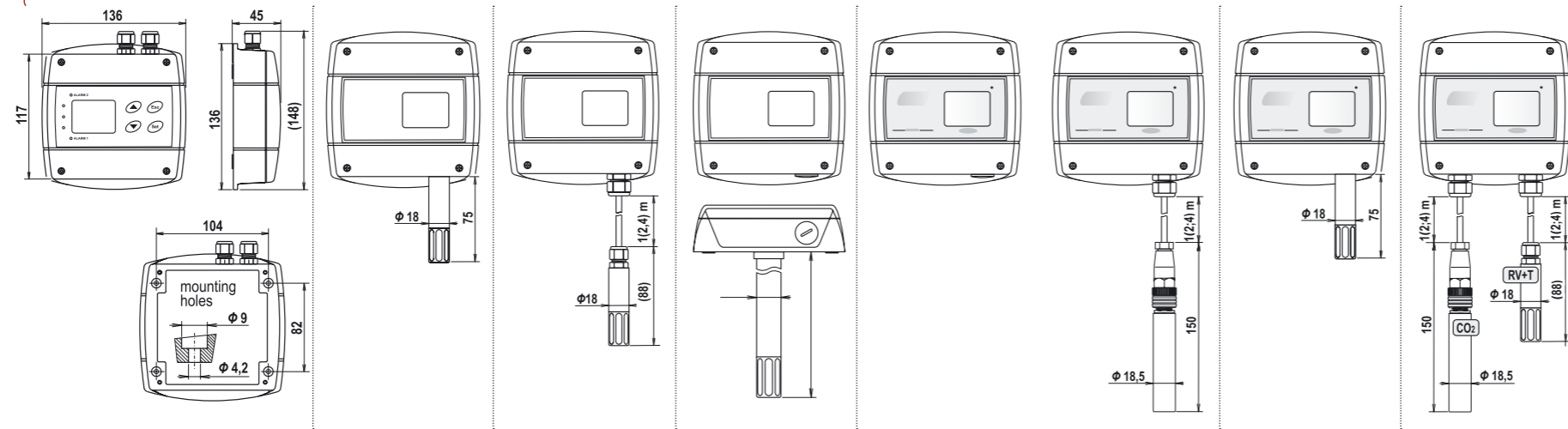

\* accuracy of relative humidity in range 5 % to 95 % and of atmospheric pressure at 23 °C

## Computed values

**Specific humidity**  
Accuracy: ±2.1 g/kg at ambient  
temperature T < 35 °C  
Range: 0 to 550 g/kg

**Dew point temperature**  
Accuracy: ±1.5 °C at ambient  
temperature T < 25 °C and  
relative humidity RH > 30 %,  
for more details see manual  
Range: -60 to +80 °C  
(-76 to 176 °F)

**Absolute humidity**  
Accuracy: ±3 g/m<sup>3</sup> at ambient  
temperature T < 25 °C  
for more details see manual  
Range: 0 to 400 g/m<sup>3</sup>

**Mixing ratio**  
Accuracy: ±2.2 g/kg at ambient  
temperature T < 35 °C  
Range: 0 to 995 g/kg

**Specific enthalpy**  
Accuracy: ± 4kJ/kg at ambient  
temperature T < 25 °C  
Range: 0 to 995 kJ/kg

## Device with PoE - connection procedure

Ethernet interface with PoE

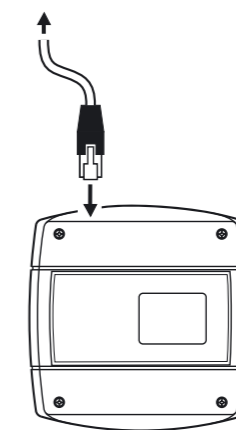

## Universal holder for probes



**MP047**  
Universal holder for probes  
for easy mounting to rack 19".

# Premium Web Sensors

**With relays & three two-states inputs**

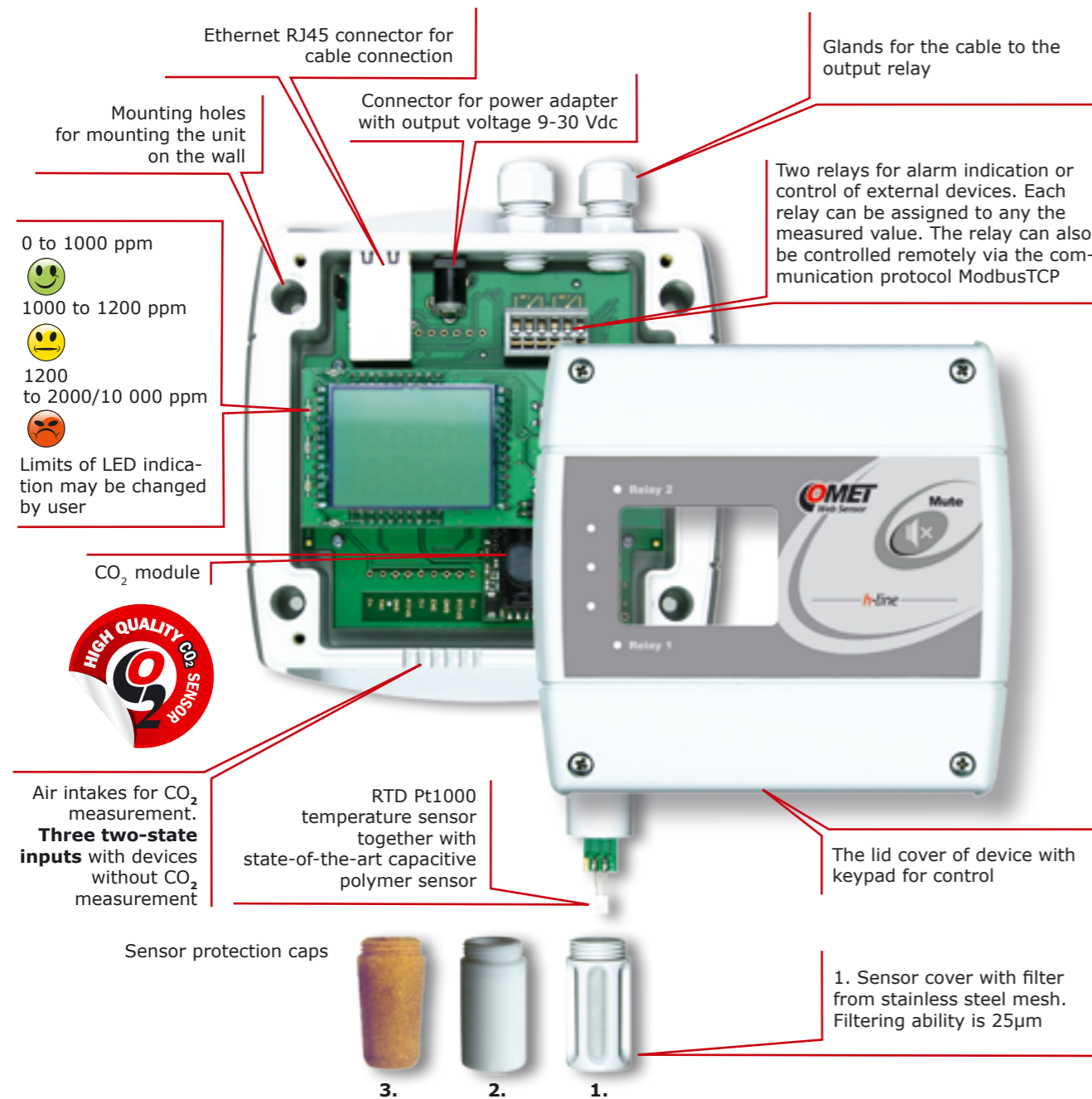

**designed for 19" rack mounting**

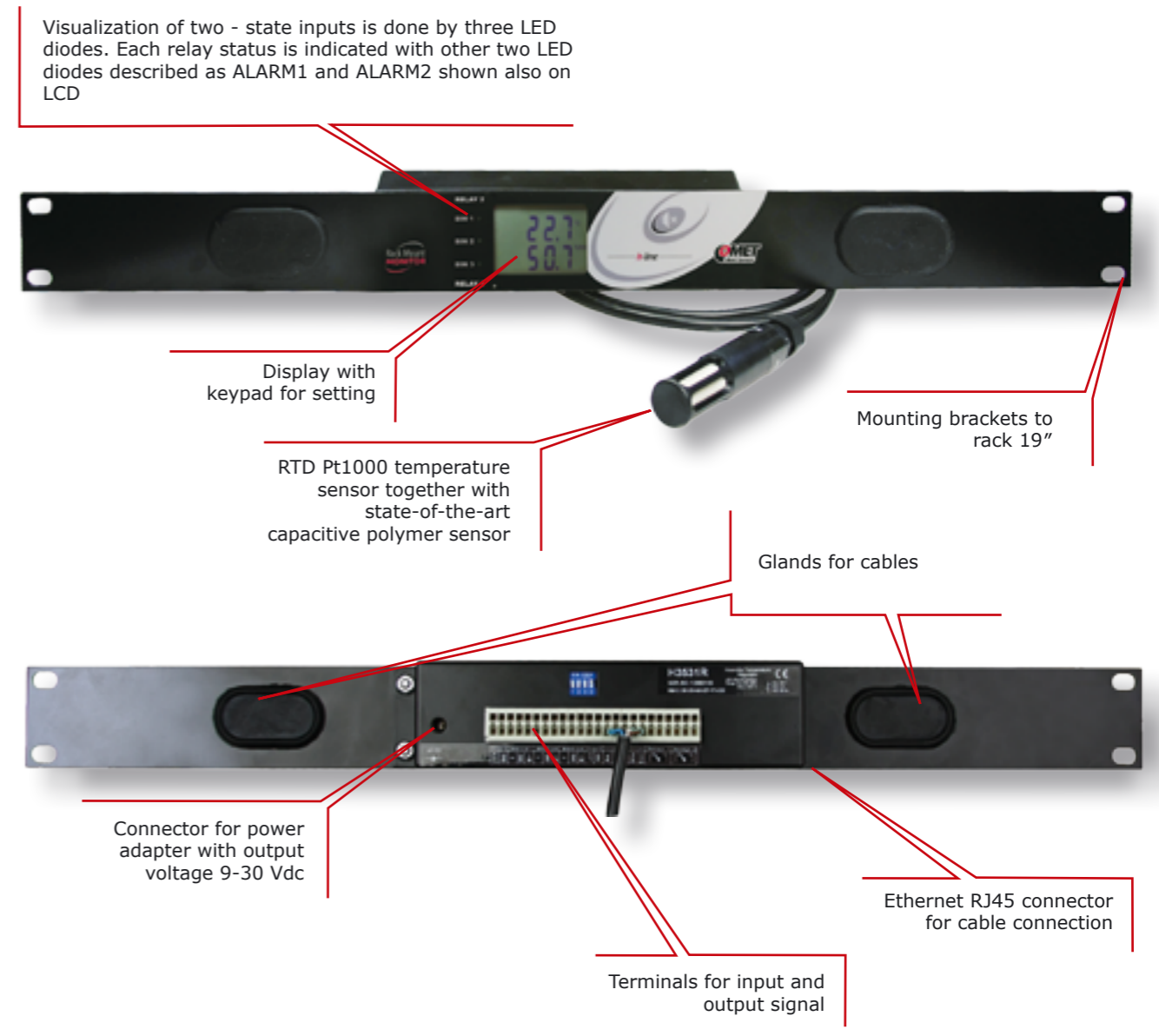

## Two-state detectors





Measured values	Temperature		Temperature, relative humidity			Temperature, relative humidity, atm. pressure		Temperature, relative humidity, CO <sub>2</sub>		Temperature	Temperature, relative humidity		
	SENSOR MODEL	H4531	H0530	H3530	H3531	H3531P	H7530	H7531	H6520	H5524	H5521	H4531R	H3531R
temperature	range	-200 to +600 °C	-30 to +80 °C	-30 to +80 °C	-30 to +105 °C		-30 to +80 °C	-30 to +105 °C	-30 to +80 °C	-	-	-200 to +600 °C	-30 to +105 °C
	accuracy	±0.2 °C without temp. probe	±0.4 °C	±0.4 °C	±0.4 °C		±0.4 °C	±0.4 °C	±0.4 °C	-	-	±0,2 °C without temperature probe	±0.4 °C
relative humidity**	range	-	-	0 to 100 % RH	0 to 100 % RH		0 to 100 % RH	0 to 100 % RH	0 to 100 % RH	-	-	-	0 to 100 % RH
	accuracy	-	-	±2.5 % RH	±2.5 % RH		±2.5 % RH	±2.5 % RH	±2.5 % RH	-	-	-	±2.5 % RH
atmospheric pressure**	range	-	-	-	-		600 to 1100 hPa	600 to 1100 hPa	-	-	-	-	-
	accuracy	-	-	-	-		±1.3 hPa	±1.3 hPa	-	-	-	-	-
CO <sub>2</sub> ***	range	-	-	-	-		-	-	0 to 2000 ppm*	0 to 2000 ppm*	0 to 10 000 ppm	-	-
	accuracy	-	-	-	-		-	-	± (50 ppm+2 % of measured value)		± (110 ppm +5 % of measured value)	-	-
relay output max. switching voltage, current, power	50 V, 2 A, 60 VA	50 V, 2 A, 60 VA	50 V, 2 A, 60 VA	50 V, 2 A, 60 VA		50 V, 2 A, 60 VA	50 V, 2 A, 60 VA	50 V, 2 A, 60 VA	50 V, 2 A, 60 VA	50 V, 2 A, 60 VA	50 V, 2 A, 60 VA	50 V, 2 A, 60 VA	50 V, 2 A, 60 VA
computed humidity values	NO	NO	YES	YES		YES	YES	YES	NO	NO	NO	NO	YES
supply voltage	9-30 V	9-30 V	9-30 V	9-30 V		9-30 V	9-30 V	9-30 V	9-30 V	9-30 V	9-30 V	9-30 V	9-30 V
recommended calibration interval	two years	two years	one year	one year		one year	one year	one year	five years	five years	two years	one year	
protection class of the case with electronics	IP40	IP40	IP40	IP40		IP40	IP40	IP40	IP30	IP30	IP30	IP30	IP30
protection class of the sensor cover	-	-	IP40	IP40		IP40	IP40	IP40	-	IP65	-	-	IP40
temperature operating range of the case with electronics	-30 to +80 °C	-30 to +80 °C	-30 to +80 °C	-30 to +80 °C		-30 to +80 °C	-30 to +80 °C	-30 to +80 °C	-30 to +60 °C	-30 to +60 °C	-30 to +80 °C	-30 to +80 °C	-30 to +80 °C
temperature operating range of the measuring element	-	-	-30 to +80°C	-30 to +105°C		-30 to +80 °C	-30 to +105 °C	-30 to +80 °C	-	-40 to +60 °C	-	-	-30 to +10 5°C
humidity operating range without condensation	0 to 100 % RH	0 to 100 % RH	0 to 100 % RH	0 až 100 % RH		0 to 100 % RH	0 to 100 % RH	0 to 95 % RH	5 to 95 % RH	0 to 100 % RH	0 to 100 % RH	0 to 100 % RH	0 to 100 % RH
barometric pressure operating range	-	-	-	-		up to 2.5 MPa	-	-	850 to 1100 hPa	850 to 1100 hPa	850 to 1100 hPa	-	-

\* Custom range 10000 ppm for an extra fee

\*\* accuracy of relative humidity in range 5 % to 95 % and of atmospheric pressure at 23 °C

\*\*\* accuracy of CO<sub>2</sub> concentration of measurement at 25 °C and 1013 hPa

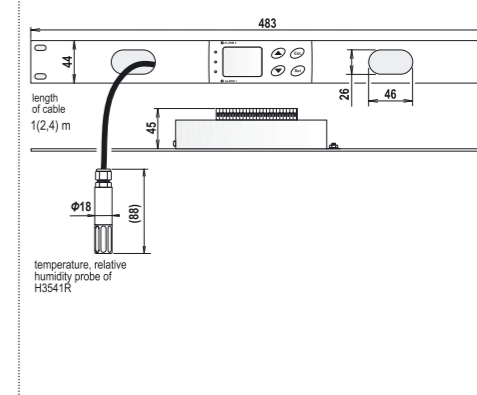
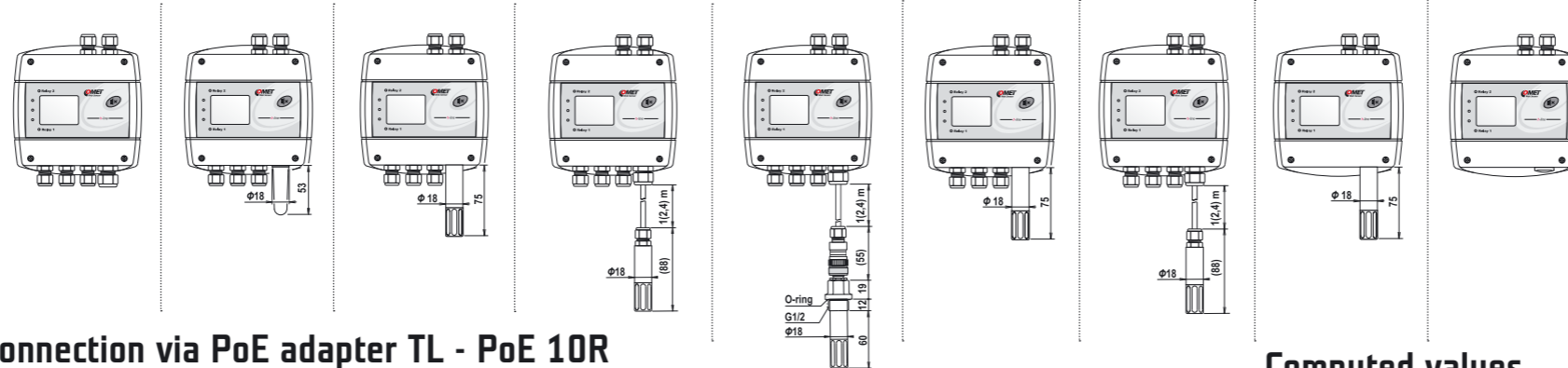
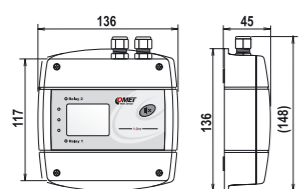

### Electrical wiring

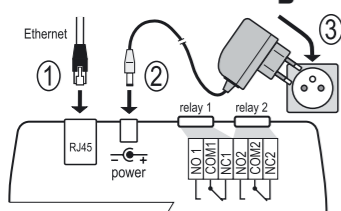

### Connection via PoE adapter TL - PoE 10R

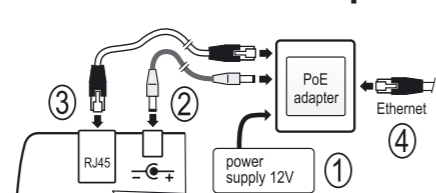

**Specific humidity**  
Accuracy: ±2.1 g/kg at ambient temperature T < 35 °C  
Range: 0 to 550 g/kg

**Dew point temperature**  
Accuracy: ±1.5°C at ambient temperature T < 25 °C and relative humidity RH > 30 %, for more details see manual  
Range: -60 to +80 °C (-76 to 176 °F)

**Absolute humidity**  
Accuracy: ±1.5 g/m<sup>3</sup> at ambient temperature T < 25 °C  
for more details see manual  
Range: 0 to 400 g/m<sup>3</sup>

**Mixing ratio**  
Accuracy: ±2 g/kg at ambient temperature T < 35 °C  
Range: 0 to 995 g/kg

**Specific enthalpy**  
Accuracy: ± 3 kJ/kg at ambient temperature T < 25 °C  
Range: 0 to 995 kJ/kg

# Economy Web Sensors

**With PoE**

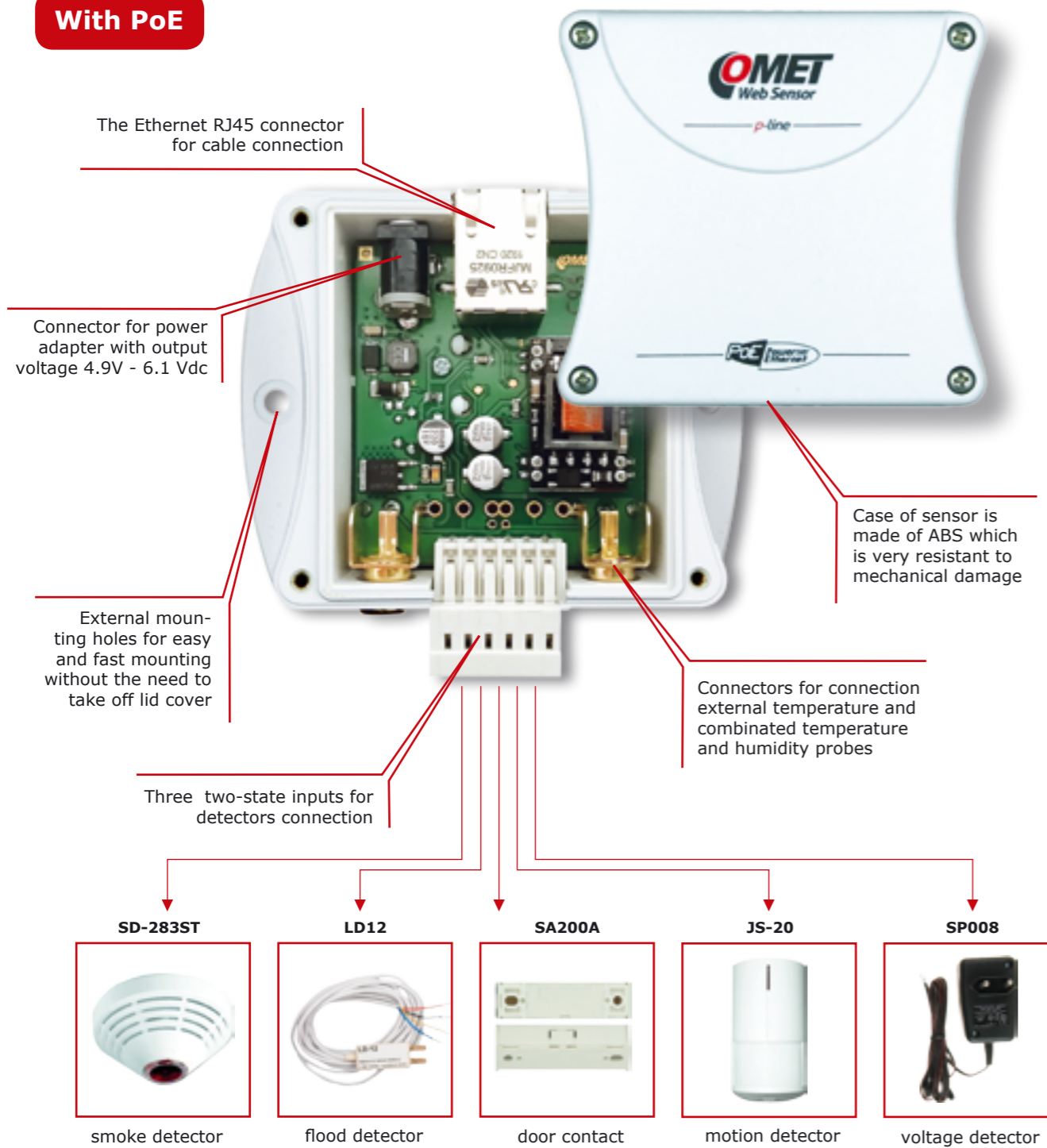

### Sensor models:

MEASURED VALUES	without PoE**	with PoE**
temperature	P8510	P8610
temperature + relative humidity*	P8511, P8541	P8641, P8611
temperature + relative humidity* + two - state inputs	P8552	P8652
0-20mA (4-20 mA)	P2520	

\* With the attached temperature and humidity probe - type DSRH (max. length 10 metres)

\*\* Please see page 20 - 21 for sensor specification

## External digital temperature probes

Temperature probes on the cable are designed to measure the temperature in specific applications. Probes are supplied in lengths of 1, 2, 5 and 10 meters (15 and 20 meters for DSTR162/C). The maximum sum of the lengths of all probes is 40m which can be connected to one device.

Fast response air probe with without protection against moisture.

### DST/C

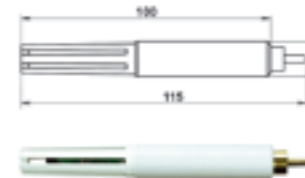

range (0°C to +50°C)  
accuracy ±0.5°C

Multi-purpose watertight probe with IP67.

### DSTGL40/C

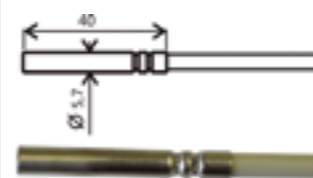

range (-30°C to +80°C)  
accuracy ±0.5°C from  
-10°C to +80°C;  
otherwise ±2°C

Universal temperature watertight probe for monitoring higher temperature.

### DSTG8/C



range (-50°C to +125°C)  
accuracy ±0.5°C from  
-10°C to +80°C;  
otherwise ±2°C

Inexpensive probe with plastic housing, slow response and with IP67.

### DSTR162/C

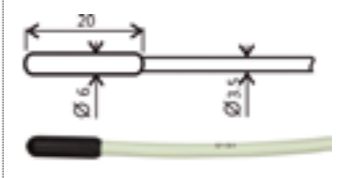

range (-30°C to +80°C)  
accuracy ±0.5°C from  
-10°C to +80°C;  
otherwise ±2°C

## External temperature/humidity probes

Fast response probe without protection against moisture.

### DSRH/C

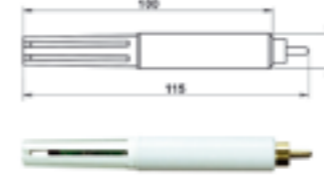

temperature  
range (0°C to +50°C)  
accuracy ±0.5°C  
humidity  
range (0 to 100 % RH)  
accuracy ±3.5 % RH

The external probe with cable length 1,2,5 and 10 meters. The probe with interchangeable sensor covers.

### DSRH



temperature  
range (0°C to +50°C)  
accuracy ±2°C  
humidity  
range (0 to 100 % RH)  
accuracy ±3.5 % RH



**F5300** - Teflon (PTFE) sensor cover (white colour), with increased resistance against splashing water, non-absorbent surface, does not rust. Porous size 25µm.



**F0000** - sintered bronze sensor cover for moderate aggressive environments. Filtering ability 25µm.



**F5200** - sensor cover with filter from stainless steel mesh, suitable for moderately dusty environment.

Measured values		Temperature	Temperature, relative humidity			Current - mA
SENSOR MODEL		P8510/ P8610	P8511/P8611	P8541/P8641	P8552/P8652	P2520
temperature	range	-30 to +80 °C/ -20 to +60 °C	according to the used probe*	according to the used probe*	according to the used probe*	-
	accuracy	±0.8 °C (> -10 °C) ±2 °C (< -10 °C)	according to the used probe*	according to the used probe*	according to the used probe*	-
relative humidity	range	-	according to the used probe*	according to the used probe*	according to the used probe*	-
	accuracy	-	according to the used probe*	according to the used probe*	according to the used probe*	-
two - state input, no galvanic isolation		-	-	-	3	-
configuration Dry contact/ Voltage input		-	-	-	YES	-
current measuring range		-	-	-	-	0-25mA(max.30mA)
accuracy of current measurement		-	-	-	-	±0.1 % FS from (0 °C do +50 °C) ±0.3 % FS from (-30 °C do+80 °C)
resolution		-	-	-	-	1uA
input impedance		-	-	-	-	20Ω
supply voltage		9-30 V / 4,9 - 6,1V	9-30 V / 4,9 - 6,1V	9-30 V / 4,9 - 6,1V	4,9 - 6,1V	9-30 V
power over Ethernet (PoE) according to IEEE 802.3af		- / YES	-	- / YES	- / YES	-
recommended calibration interval		two years	according to the used probe*	according to the used probe*	according to the used probe*	two years
protection class of the case with electronics		IP30	IP30	IP30	IP30	IP30
temperature operating rangeof the case with electronics		-30 to +80 °C / -20 to +60 °C	-30 to +80 °C / -20 to +60 °C	-30 to +80 °C / -20 to +60 °C	-20 to +60 °C	-30 to +80 °C
humidity operating range without condensation		0 do 100 % RV	0 do 100 % RV	0 do 100 % RV	0 do 100 % RV	0 do 100 % RV

## Solution for third party sensors

P2520 two channel current loop converter is designed to connect sensors with output 4-20mA / 0-20 mA into Ethernet network. The current signal can be recalculated to physical values measured by the connected sensors. Sensors can be powered directly from the P2520 converter.

- » Measured values can be read by means of Ethernet connection.
- » The instrument may also send a warning message if the measured value exceeds adjusted limit.
- » The device setup can be made by the www interface.

**P2520**



signal input  
0 - 20 mA

signal input  
0 - 20 mA

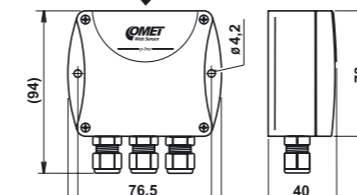
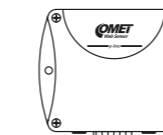
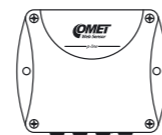
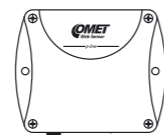
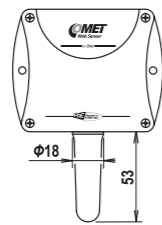
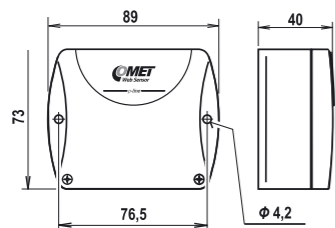

**MP047**  
Universal holder for probes  
for easy mounting to rack 19".

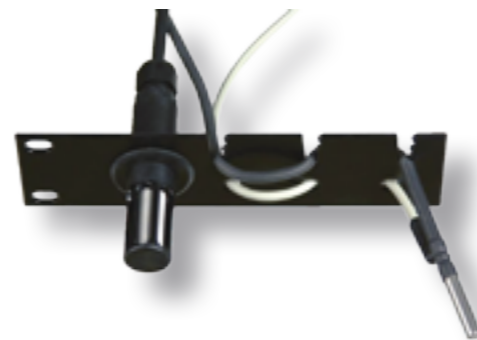

**MP046**  
Universal holder for P8xxx  
and Tx5xx Web Sensors for  
easy mounting to rack 19".



**A1825**  
Switching power  
supply unit for Web  
Sensors P8xxx and  
Tx6xx.

# COMET Cloud and Database software

## Data storage place for COMET sensors

For users of Web Sensors a solution for data collection to one central place is available. It can be software solution based on MS SQL and installed on customer's server or personal computer. The second option how to collect measured data is COMET Cloud which accessible from any device with web browser.



- 24 - hour supervision
- unlimited data storage
- simple and clear access to your measured values
- single repository for all devices COMET
- alarm SMS texts and e-mails
- acoustic and visual signalization of alarms

Each purchased COMET Database already contains one licence of Database Viewer This low cost browser enables several clients to view database from different places on internal network or internet. Other viewer licences can be purchased separately for other users of COMET Database.

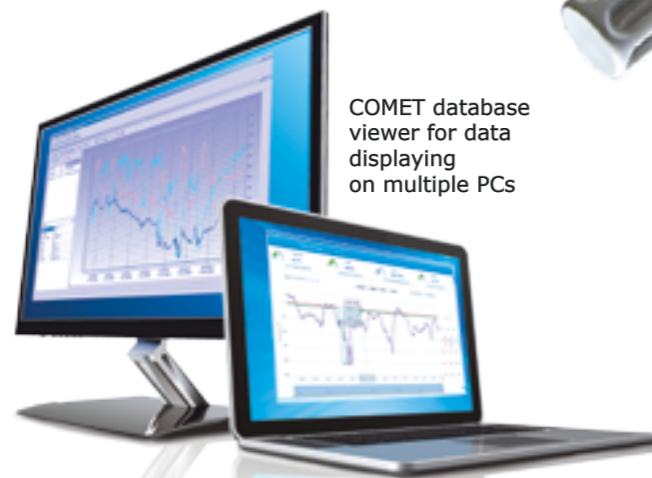

COMET database viewer for data displaying on multiple PCs

COMET Database also exists in 30 days trial version. So you can test it without any worries.

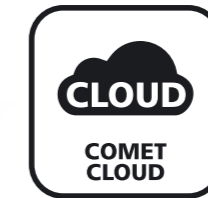
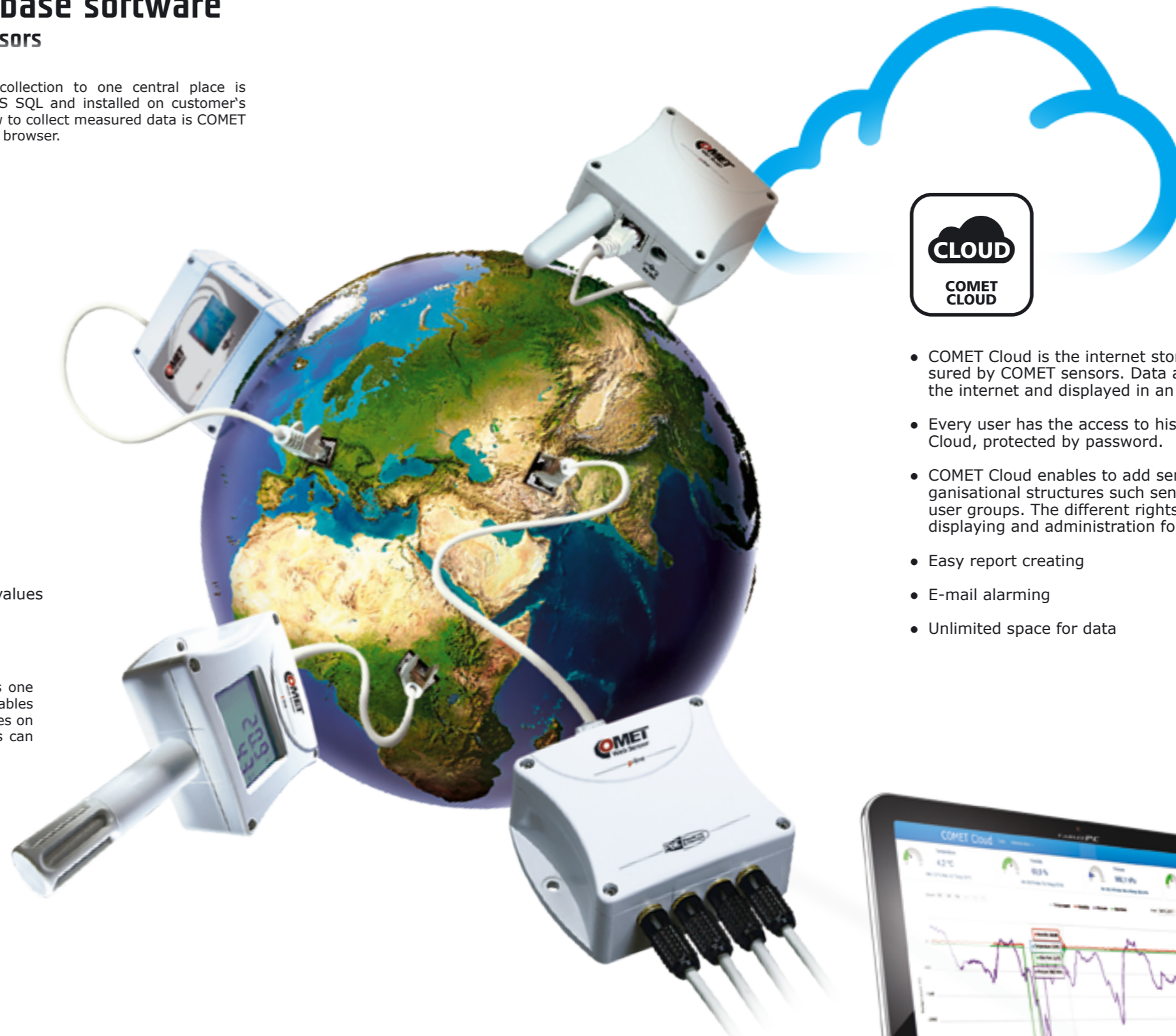

- COMET Cloud is the internet storage of data measured by COMET sensors. Data are accessible in the internet and displayed in an internet browser.
- Every user has the access to his account COMET Cloud, protected by password.
- COMET Cloud enables to add sensors, creates or ganisational structures such sensor groups and user groups. The different rights can be set up for displaying and administration for each user.
- Easy report creating
- E-mail alarming
- Unlimited space for data



Web browser for data displaying

# WEB SENSORS

On-line monitoring and alarm indication

Temperature | Humidity | Dewpoint |  
Bar. pressure | CO<sub>2</sub> | Current | Events



The COMET System, s.r.o. company is continuously developing and improving its product. COMET System, s.r.o. reserves the right to carry out technical changes in equipment or product without any previous notice.

COMET SYSTEM, s.r.o.  
Bezrucova 2901  
756 61 Roznov pod Radhostem  
CZECH REPUBLIC  
Tel: +420-571653990  
E-mail: [info@cometsystem.com](mailto:info@cometsystem.com)  
[www.cometsystem.com](http://www.cometsystem.com)